

SCIENCE MEETS TECHNOLOGY

FCT Sintering plants

HOT PRESSES

FAST/SPS

GAS PRESSURE SINTERING

VAKUUM SINTERING

HYBRID TECHNOLOGY

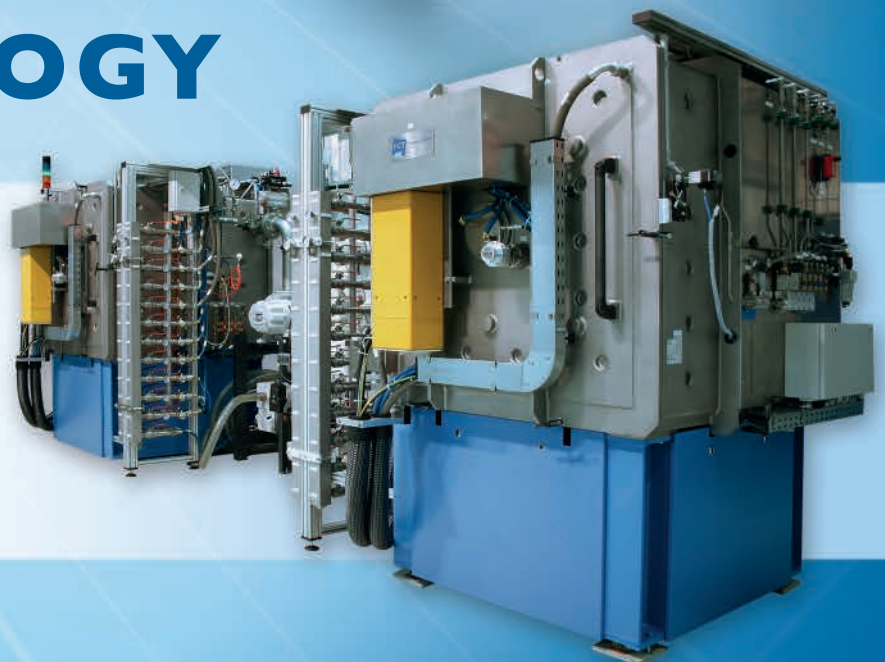

PRODUCT INNOVATIONS

SCIENCE MEETS TECHNOLOGY

DESIGN – For more than 40 years, we have been designing customised high-temperature plants for the production of innovative high-performance materials.

MANUFACTURING – We manufacture sintering systems developed in accordance with the latest scientific findings and based on our extensive experience.

RESEARCH – Our in-house technical centre is constantly improving and developing innovative plant concepts and sintering processes.

PERFECT SYMBIOSIS – Efficient high-performance plants that achieve maximum service life and low operating costs: high quality made in Germany.

LEARN MORE – See for yourself and learn more about our company and products.



CONTENTS

About FCT	Page	Page
System Concepts	4	11. Pyrometer in Quotient Measurement Mode 25
Sintering Technologies / Technical Centre	6	12. Digitally Controlled Servo-Hydraulics 26
Innovative Hybrid System Concepts	7	13. Dilatometer 26
Applications	8	14. Rate Controlled Sintering (via press force) 26
Products		15. Rate Controlled Sintering (via temperature controller) 27
KCE®-FCT HP P 12.5/4-LA	11	16. Fine Vacuum up to Atmospheric Pressure 27
KCE®-FCT FPW 1.25-SD	12	17. Fast Air Extraction 27
KCE®-FCT FP H 6/12.5-LA	13	18. High Vacuum 27
KCE®-FCT H-HP D 10-SD/FL	14	19. Overpressure up to 10 bar 28
KCE®-FCT H-HP D 25-SD/FL	15	20. Overpressure up to 100 bar 28
KCE®-FCT H-HP D 60-SD	16	21. Protective gas (Ar, N ₂ , N ₂ +5%H ₂) 28
KCE®-FCT H-HP D 320-SD	17	22. Oxidising Atmosphere 28
KCE®-FCT HP D 10-SD/GB	18	23. Oxygen Partial Pressure Control 28
KCE®-FCT HPW 25-SD	19	24. Hydrogen Operation 29
Overview of available performance characteristics	20	25. Debinding 29
Description of available equipment		26. Gas Supply in Retort 29
1. Fully Automatic Operation	22	27. Semi-Continuous/ Separate Cooling Chamber 30
2. Process Visualisation	22	28. FAST/SPS (high current density) DC/pulsed DC 32
3. Self-Monitoring	23	29. FAST/SPS (high current density) AC/pulsed AC 33
4. Data Logger	23	30. Resistance Heating 34
5. Recipe Management	24	31. Induction heating 35
6. Max. Operating Temperature 2200°C	24	32. FAST/Flash (high electric field strength) DC 36
7. Max. Operating Temperature 2400°C	24	33. FAST/Flash (high electric field strength) AC 36
8. Max. Operating Temperature 3000°C	24	34. Glove Box 37
9. Pyrometer Measurement Near Sample Centre	25	35. Separate Cooling Water Supply 37
10. Pyrometer Measuring Range from 100°C	25	36. Pressing Tools, Kiln Furniture and Other Special Accessories 37

From the idea to the product

For more than 40 years, we have been designing and manufacturing high-quality, innovative high-temperature systems for the production of modern high-performance materials in Frankenblick, Thuringia. We focus on the development of customised and efficient systems that achieve maximum performance and service life. We also design comprehensive manufacturing concepts and implement complete production line projects.

We work in close collaboration with our customers to develop customised solutions for process optimisation. You benefit from the expertise of our technicians, engineers and scientists in all fields of the manufacture of high-performance materials and engineered ceramics throughout the development process. In addition, our in-house Technical Centre is constantly improving and developing innovative system concepts and sintering processes and is available for product development. Benefit from the leading edge that our experience and expert knowledge offer.

Today, FCT Systeme GmbH is a leading developer and manufacturer of sintering systems for hot pressing, spark plasma sintering, gas-pressure sintering and vacuum sintering at maximum temperatures - especially in the field of powder metallurgy and engineered ceramics. Recently, our developments have been focused on Spark Plasma Sintering Technology which creates new opportunities when exploring innovative high-performance materials. Now we can provide different system concepts from laboratory scale to large industrial scale.

Our intense research and development and close collaboration with partners in the industry and science sectors guarantee the constant high quality of our systems. Our experience, technical competence and expert knowledge allow us to consistently meet customer requirements and offer high-tech solutions at the highest level.

Thus, we produce efficient high-performance systems that achieve maximum service life and low operating costs in perfect interaction between science and technology in our factory workshops. High-quality systems. Made in Germany.

Systems and products

Portfolio

FCT SYSTEM CONCEPTS

FCT
HIGH-TEMPERATURE
EQUIPMENT AND
TECHNOLOGY



HOT PRESSES



FAST/SPS



GAS PRESSURE
SINTERING



VAKUUM
SINTERING



HYBRID
TECHNOLOGY

The Symbiosis of science and technology

We can develop sintering technologies that are precisely adapted to suit ceramic and powder metallurgical components, ready for batch production within a very short period of time thanks to the perfect combination of our Technical Centre with the best possible equipment and a highly specialised and experienced team of technicians, engineers and scientists.

The sintering systems that are available for customer projects provide the most important sintering processes in accordance with the latest technical and scientific findings. As our machinery is constantly being renewed and existing plants are being optimised and extended our Technical Centre is always state of the art.

Typically, our customer projects proceed like this:

- First contact and agreement on confidentiality
- The customer presents and clarifies the type of task.
- Practical sintering experiments are planned in a suitable plant in our Technical Centre.
- Experimental results are discussed with the customer and, if necessary, more tests are carried out.
- After achieving the desired results: planning and design of a customer-specific sintering system with precisely adapted sintering cycles.

This process and the practical proof of required specifications ensure that our customers get the exact problem solution required for the intended ceramic or powder metallurgical production processes and a high level of security of investment.

Sintering systems that are currently available for customer projects:

- FAST/Hybrid Spark Plasma Sintering System
- Gas Pressure Vacuum Hot Press
- Gas Pressure Sintering Furnace
- Vacuum Sintering Furnace

FCT TECHNICAL CENTRE

The interface between science and technology - resulting in an efficient symbiosis between theory and practice.



The ideal combination

In sintering technology, sintering units, which combine several classic sintering methods, are termed hybrid systems. For instance, in the trendsetter FAST/Hybrid (H-HP D series), the classic hot-pressing method (HP W series) has been combined with additional direct heating of the powder compact by pulsed DC (FAST/SPS). Compared to hot pressing this combination allows a further increase in heating rates and at the same time better temperature homogeneity beyond the capabilities of FAST/SPS (HP D series).

The combination of gas pressure and uniaxial pressing force (FP H and HP P series) is needed in the development and optimisation of materials and finds increasing application e.g. in the compression of high-purity materials or their synthesis. Depending on the requirements, this innovative hybrid concept allows a maximum gas pressure of up to 100 bar and, depending on the size, different maximum press forces.

Due to the unique combination of different sintering processes with the various additional options, the new FCT hybrid systems offer previously unrealisable opportunities for development and optimisation of innovative materials, e.g. for energy technology, semi-conductor industry, aerospace as well as other relevant fields.

FCT HYBRID TECHNOLOGY

Unique possibilities of combining different sintering processes for the production of innovative high-performance materials.



APPLICATIONS

Industries and products

A varied range of processes and many more areas of applications are possible.

Please contact us, we are pleased to advise you.



Bullet protection

Body protection, vehicle and helicopter armour
Hot pressing / Vacuum sintering
→ HPW / FSW / FHW



Aerospace industry

Systems for satellites
Hot pressing / Vacuum sintering
→ FPW / HPW



Automotive industry

Diesel Particulate Filters, ceramic brake discs, seal rings
Vacuum sintering
→ FHW / FH I



Research

Fundamental research, material processes
FAST (SPS), Hybrid furnaces
all - mainly → HP D / H-HP D



Renewable energy

Thermoelectrics, LED, ceramic ball bearings for wind turbines
FAST (SPS), Hybrid plants, Gas pressure sintering
→ HP D / H-HP D / FPW

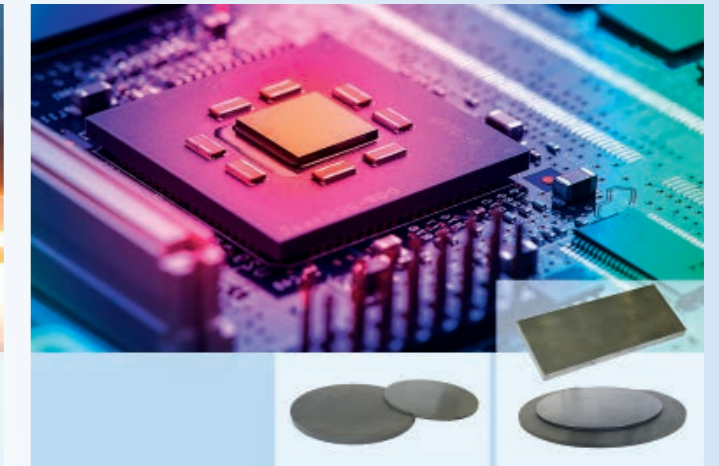

Semi-conductor industry

Sputter Targets
FAST (SPS), Hot pressing
→ HP D, HPW



Chemical industry

Seal rings, protective tubes, grinding cylinders
Hot pressing, Gas pressure sintering
→ HPW / FHW



Nuclear industry

Absorber rods for nuclear power plants
Hot pressing
→ HPW



Mechanical engineering

Ball bearings to withstand highest loads, cutting tools, various parts subject to wear
Vacuum sintering, Hot pressing, Gas pressure sintering
→ FPW / FHW / HPW

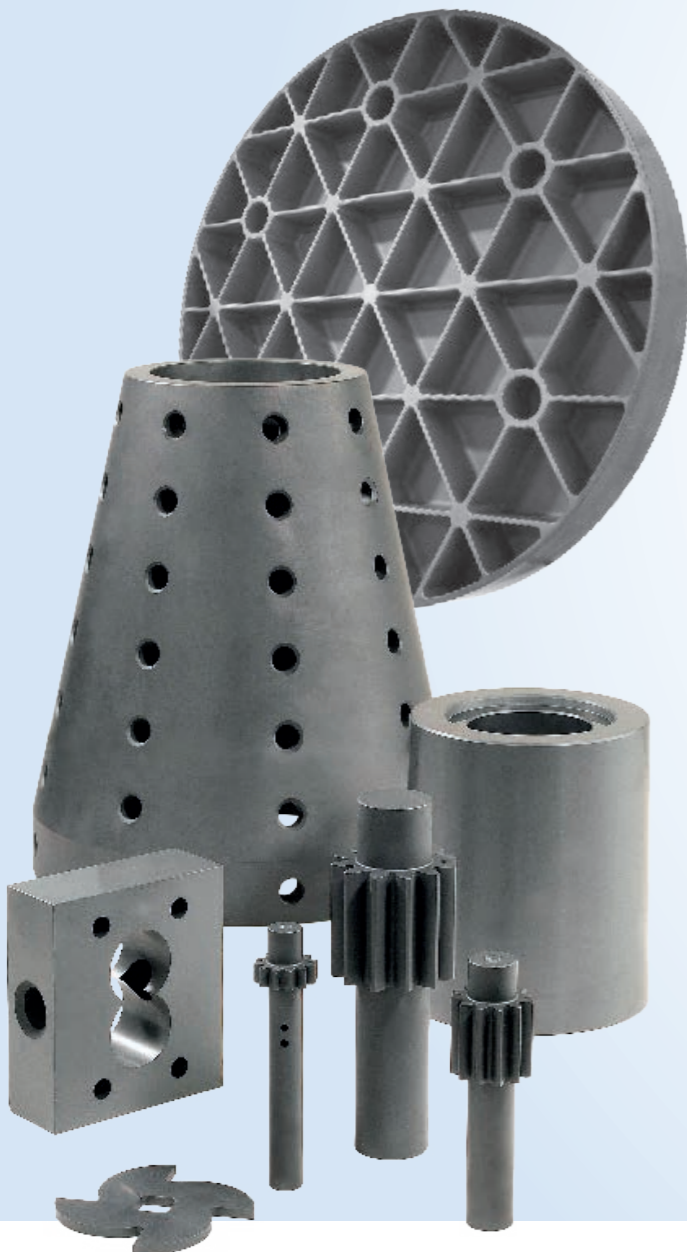

HOT PRESSES

Versatile hot pressing system with additional gas pressure function

KCE®-FCT HP P 12.5/4-LA

Description

This innovative hybrid system is a combination of classic hot pressing with gas pressure. For the development of materials such flexible systems are increasingly in demand, especially when it comes to deliberately suppressing decomposition of material systems in certain temperature ranges during hot pressing.

In addition to the hot pressing of samples with a diameter of up to 60 mm and simultaneous application of gas pressure up to 10 bar, the system can also be used both for vacuum sintering and for pressure sintering.

This high level of flexibility sets new standards, especially in the field of R&D.

Features

- Hot pressing in a vacuum, relative pressure and overpressure (up to 1 MPa)
- Sintering in vacuum, relative pressure, overpressure (up to 1 MPa)
- High flexibility in process optimisation and design
- Multi-level processes can be easily combined
- Comprehensive data analysis

Applications

- Development and optimisation of new material systems
- Prototype production
- High-grade Si₃N₄ and SiC materials



Main specifications

Useful volume	4 dm ³
Max. sintering temperature	2200°C
Max. pressing force	125 kN
Gas pressure	10 bar (1 Mpa)
Dilatometer	
Max. component diameter	60 mm
Final vacuum in the cold furnace	5 × 10 ⁻²
More information on request or at:	www.fct.systeme.de

Options

Max. operating temperature 2400°C	<input checked="" type="checkbox"/>
Rate Controlled Sintering	<input checked="" type="checkbox"/>
Air/oxygen atmosphere	<input checked="" type="checkbox"/>
Debinding (thermal oxidation)	<input checked="" type="checkbox"/>
Gas supply in retort	<input checked="" type="checkbox"/>
Induction heating	<input checked="" type="checkbox"/>
See all available options:	Overview pages 20-21

GAS PRESSURE

Laboratory gas pressure sintering furnace with additional options

KCE®-FCT FP W 1.25-SD

Description

Gas pressure sintering systems are particularly suitable for sintering ceramics or metals which tend to decompose at higher temperatures or which cannot be densely sintered by means of standard sintering processes. In this process, there are no restrictions with regard to the geometry of the components to be sintered.

In addition, such systems are increasingly being used for the synthesis of material powders for the purpose of influencing the chemical equilibrium.

Features

- Gas pressure sintering (Sinter-HIP) up to 10 MPa (option 20 MPa)
- Sintering in a vacuum or relative pressure
- High flexibility in process optimisation and design
- Multi-level processes can be easily combined
- Comprehensive data analysis

Applications

- Development and optimisation of new material systems
- Prototype production
- Optimisation of the sintering behaviour with in situ dilatometers
- Material synthesis



Main specifications

Useful volume	1.25 dm ³
Max. sintering temperature	2200°C
Operating pressure	100 bar (10 MPa)
Process gases	Ar, N ₂ , Forming gas
Final vacuum in the cold furnace	5 × 10 ⁻²
More information on request or at:	www.fct.systeme.de

Options

Max. operating temperature 2400°C	●
Digitally controlled servo-hydraulics	●
Dilatometer	●
Debinding (thermal oxidation)	●
Gas supply in retort	●
TC Control RT...1700°C	●
See all available options:	Overview pages 20-21

GAS PRESSURE

Versatile gas pressure sintering system with additional hot pressing function

KCE®-FCT FP H 6/12.5-LA

Description

In addition to classic gas pressure sintering, which is also known as Sinter-HIP, this furnace type is marked in particular by its high flexibility and the possibility of combining with other sintering processes.

Sintering under vacuum and relative pressure can be implemented as well as original gas pressure sintering up to 100 bar as well as the combination of all these different sintering atmospheres with uniaxial hot pressing.

Features

- Gas pressure sintering (Sinter-HIP) up to 10 MPa (option 20 MPa)
- Sintering in a vacuum or relative pressure
- Hot pressing up to 125 kN, max. sample diameter 70 mm
- High flexibility in process optimisation and design
- Multi-level processes can be easily combined
- Comprehensive data analysis

Applications

- Development and optimisation of new material systems
- Prototype production
- Synthesis processes for LED



Main specifications

Useful volume	6 dm ³
Max. sintering temperature	2200°C
Max. pressing force	125 kN
Gas pressure	100 bar (10 MPa)
Max. component diameter	70 mm
Final vacuum in the cold furnace	5 × 10 ⁻²
More information on request or at:	www.fct.systeme.de

Options

Max. operating temperature 2400°C	●
Dilatometer	●
Rate controlled Sintering (via press)	●
Debinding (thermal oxidation)	●
Gas supply in retort	●
Induction heating	●
See all available options:	Overview pages 20-21

FAST/SPS HYBRID SYSTEM

Versatile FAST/SPS hybrid system with additional flash function

KCE®-FCT H-HP D 10-SD/FL

Description

Our Flash Spark Plasma Sintering System KCE®-FCT H-HP D 10-FL has been developed to allow the compaction of a wide range of raw materials in powder form using uniaxial compression forces and heating by direct passage of current (DC pulses). In addition, heating can be direct via a radial heater (resistance/induction) as well as indirectly, which in turn is the prerequisite for applying the optionally available flash sintering or flash forging.

Flash sintering/Flash forging offers you another way of compressing at much higher voltage than the conventional FAST/SPS.

All three compaction methods can be combined as needed to maximise flexibility, especially in R&D applications.

Features

- FAST/SPS sintering with pulsed DC
- Hot pressing
- Combination of FAST/SPS with hot pressing
- Flash sintering/Flash forging
- All sintering processes can be carried out under vacuum or relative pressure (inert gas)
- Pyrometer measurement near the sample centre

Applications

- Development and optimisation of new material systems
- Prototype production
- Ultrafast sintering process
- Prevention of grain growth (ultra-fine microstructure)



Main specifications

Max. pressing force	100 kN
Max. component diameter	60 mm
Max. sintering temperature	2200°C
Max. heating rate	up to 1000 K/min
Final vacuum in the cold furnace	5×10^{-2}
Max. FAST/SPS voltage	8 V
Max. FLASH voltage	180 V
Max. radial heater power	27 kW
More information on request or at:	www.fct.systeme.de

Options

Max. operating temperature 2400°C	●
Dilatometer	●
Rate Controlled Sintering (via press)	●
FAST/SPS (high current density) AC/pulsed AC	●
FAST/Flash (high electric field)	●
FAST/Flash (high electric field)	●
See all available options:	Overview pages 20-21

FAST/SPS HYBRID SYSTEM

Versatile FAST/SPS hybrid system with additional flash function

KCE®-FCT H-HP D 25-SD/FL

Description

As a further development of our H-HP D 10-SD / FL, this type of system was launched on the market in order to transfer knowledge from basic research into product development and prototype production. Particular attention was paid to the ease of operation of the system and high reproducibility of the processes.

Features

- FAST/SPS sintering with pulsed DC
- Hot pressing
- Combination of FAST/SPS with hot pressing
- Flash sintering/Flash forging
- All sintering processes can be carried out under vacuum or relative pressure (inert gas)
- Pyrometer measurement near the sample centre

Applications

- Component development
- Prototype production
- Nanomaterials can be sintered without appreciable grain growth
- FGM ("Functionally Graded Materials")
- Composite materials
- Innovative carbides
- Metal alloys as well as intermetallic compounds
- Structural and functional ceramics



Main specifications

Max. pressing force	250 kN
Max. component diameter	100 mm
Max. sintering temperature	2200°C
Max. heating rate	up to 1000 K/min
Final vacuum in the cold furnace	5×10^{-1}
Max. continuous output	80 kW
Max. FLASH voltage	180 V
Max. FAST/SPS voltage	8 V
More information on request or at:	www.fct.systeme.de

Options

Max. operating temperature 2400°C	●
Dilatometer	●
Rate Controlled Sintering (via press)	●
FAST/SPS (high current density) AC/pulsed AC	●
FAST/Flash (high electric field) DC	●
FAST/Flash (high electric field) AC	●
See all available options:	Overview pages 20-21

Spark Plasma Sintering System

KCE®-FCT HP D 60-SD

Description

In this sintering process, the tool or component is heated by the direct passage of current, so that cycle times of a few minutes are possible.

The use of DC pulses leads to an additional increase in the sintering activity of many materials due to the processes (Joule heating, plasma formation, electromigration, etc.) occurring at the points of contact of the powder particles, so that significantly lower temperatures and/or pressing power is required than in conventional hot pressing or sintering.

Features

- FAST/SPS sintering with pulsed direct current
- Hot pressing (optional)
- Combination of FAST/SPS with hot presses (optional)
- All sintering processes can be carried out under vacuum or relative pressure (inert gas)
- Pyrometer measurement near the sample centre

Applications

- Development and optimisation of new material systems
- Prototype production
- Ultrafast sintering process allows compacting of nanomaterials without appreciable grain growth
- FGM ("Functionally Graded Materials")
- Composite materials
- Innovative carbides
- Aluminium and copper alloys as well as intermetallic compounds
- Structural and functional ceramics



Main specifications

Max. pressing force	600 kN
Max. r component diameter	120 mm
Max. sintering temperature	2200°C
Max. heating rate	up to 1000 K/min
Final vacuum in the cold furnace	5 x 10 ⁻²
Max. FAST/SPS voltage	8 V
Max. SPS continuous output	120 kW
More information on request or at:	www.fct.systeme.de

Options

Max. operating temperature 2400°C	●
Digitally controlled servo-hydraulics	●
Dilatometer	●
Rate Controlled Sintering (via press force)	●
FAST/SPS (high current density) AC/pulsed AC	●
Induction heating	●
See all available options:	Overview pages 20-21

FAST/SPS Hybrid Production System
(FAST/SPS + radial heater)

KCE®-FCT H-HP D 320-SD

Description

The concept of this hybrid hot press/FAST/SPS system with 3200 kN pressing force was developed for the special requirements, up to temperatures of 2200°C, in the production of metallic and ceramic materials, but also for composites, functional graded materials (FGM), carbides and especially "nanomaterials". Here, the aspect of "large components" production technology is in the foreground (sputter targets, ballistic materials, etc.) whereby the advantages of hybrid technology, namely the application of the two heating systems (radial/direct) to achieve a high temperature uniformity within the component come fully into effect here.

Features

- FAST/SPS sintering with pulsed DC
- Hot pressing
- Hybrid using both heating systems simultaneously
- All processes in a vacuum or relative pressure
- Comprehensive data analysis
- Pyrometer measurement near the sample centre

Applications

- Industrial production of large-size components
- Especially for materials such as:
 - Composites
 - Functionally graded materials (FGM)
 - Carbides
 - Nanomaterials



Main specifications

Max. pressing force	3200 kN
Max. component diameter	400 mm
Max. sintering temperature	2200°C
Max. heating rate	up to 600 K/min
Final vacuum in the cold furnace	5 x 10 ⁻²
Max. continuous output	350 kW
Max. SPS continuous output	350 kW
More information on request or at:	www.fct.systeme.de

Options

Max. operating temperature 2400°C	●
Digitally controlled servo-hydraulics	●
Dilatometer	●
Rate Controlled Sintering (via press force)	●
Semi-continuous/Separate cooling chamber	●
Resistance heating	●
See all available options:	Overview pages 20-21

FAST/SPS HYBRID SYSTEM

Spark Plasma Sintering System with Glove Box

KCE®-FCT HP D 10-SD/GB

Description

Many years ago, we launched the HP D series Spark Plasma Sintering System, which sinters various materials, preferably in powder form, using uniaxial pressing forces and heating with direct passage of current (DC pulses).

This series have now been extended by a glove box version due to steadily increasing demands on the part of the materials to be processed (sensitivity to oxygen and/or humidity). Thus, it is now possible to carry out the sample preparation and postprocessing directly in the glove box and to load it from there into the process chamber without an intermediate station.

Features

- FAST/SPS sintering with pulsed DC
- All handling/sintering processes under a protective gas atmosphere and/or vacuum.
- High flexibility in process optimisation and design
- Comprehensive data analysis
- Pyrometer measurement near the sample centre

Applications

- Development and optimisation of new material systems
- Prototype production
- Ultrafast sintering process
- Prevention of grain growth (ultra-fine microstructure)
- Especially for the processing of sensitive materials



Main specifications

Max. pressing force	100 kN
Max. component diameter	50 mm
Max. sintering temperature	2200°C
Max. heating rate	up to 1000 K/min
Final vacuum in the cold furnace	5×10^{-2}
Max. FAST/SPS voltage	7,2 V
Max. SPS continuous output	37 kW
More information on request or at:	www.fct.systeme.de

Options

Max. operating temperature 2400°C	●
Dilatometer	●
Rate Controlled Sintering (via press force)	●
FAST/SPS (high current density) AC/pulsed AC	●
See all available options:	Overview pages 20-21

HOT PRESSING

Laboratory Vacuum Hot Press

KCE®-FCT HP W 25-SD

Description

The concept of this universal hot press for temperatures up to 2200°C has been developed to meet the requirements of laboratories for the development of new materials at very high temperatures. In addition to the basic function, namely hot pressing with graphite moulds, the system also offers the possibility to perform sintering tests under vacuum, normal pressure and slightly elevated gas pressure.

Features

- Hot pressing in vacuum or relative pressure
- Sintering in a vacuum or relative pressure
- High flexibility in process optimisation and design
- Multi-level processes can be easily combined
- Comprehensive data analysis

Applications

- Product development & prototype production from:
 - Silicon nitride, mixed ceramics made of Al_2O_3 , titanium carbon nitride TiC/TiN and SiAlON for cutting tools, components for high load valves, bearings, wear parts for process engineering, etc.
 - PLZT (lead lanthanum zirconium titanate) and other advanced functional ceramics (O_2 atmosphere)
 - Boron carbide B4C for extremely wear-resistant components and armours
 - SiC whisker reinforced Al_2O_3 for cutting tools
 - MMC and CMC materials, composite materials
 - Sputter targets



Main specifications

Max. pressing force	250 kN
Max. press diameter	80 mm
Final vacuum in the cold furnace	5×10^{-1}
Max. sintering temperature	2200°C
Heat output	40 kW
More information on request or at:	www.fct.systeme.de

Options

Max. operating temperature 2400°C	●
Dilatometer	●
Rate Controlled Sintering (via press force)	●
Debinding	●
Gas supply in retort	●
See all available options:	Overview pages 20-21

OVERVIEW OF AVAILABLE PERFORMANCE CHARACTERISTICS

● = Standard
○ = Option

	Performance Characteristic	1.	2.	3.	4.	5.	6.	7.	8.	9.	10.	11.	12.	13.	14.	15.	16.	17.	18.	19.	20.	21.	22.	23.	24.	25.	26.	27.	28.	29.	30.	31.	32.	33.	34.	35.	36.
		Fully Automatic Operation	Process Visualisation	Self-Monitoring	Data Logger	Recipe Management	Max. Operating Temperature 2200°C	Max. Operating Temperature 2400°C	Max. Operating Temperature 3000°C	Pyrometer Measurement Near Sample Centre	Pyrometer Measuring Range From 100°C	Pyrometer in Quotient Measurement Mode	Digitally Controlled Servo-Hydraulics	Dilatometer	Rate Controlled Sintering (via press force)	Rate Controlled Sintering (via temperature controller)	Fine Vacuum up to Atmospheric Pressure	Fast Air Extraction	High Vacuum	Overpressure up to 10 bar	Overpressure up to 100 bar	Protective gas (Ar, N2, N2+5%H2)	Oxidising Atmosphere	Oxygen Partial Pressure Control	Hydrogen Operation	Debinding	Gas Supply in Retort	Semi-Continuous/Separate Cooling Chamber	FAST/SPS (high current density) DC/pulsed DC	FAST/SPS (high current density) AC/pulsed AC	Resistance Heating	Induction Heating	FAST/Flash (high electric field strength) DC	FAST/Flash (high electric field strength)	Glove Box	Separate Cooling Water Supply	Pressing Tools, Kiln Furniture and Other Special Accessories
High temperature pressure sintering furnace (Sinter-HIP)	FP W	●	●	●	●	●	●	○	○		○	○	●	○		○	○	○	○	○	○	○	○	○	○	○	○			●	○				○	○	
High temperature pressure sintering furnace with hot press	FP H	●	●	●	●	●	●	○	○	○	○	○	●	●	●	○	○	○	○	○	○	○	○	○	○	○	○			●	○	○	○	○		○	○
Hot press	HP W	●	●	●	●	●	●	○	○	○	○	○	●	●	●	○	○	○	○	○	○	○	○	○	○	○	○			●	○	○	○	○	○	○	○
Multipurpose hot press	HP P	●	●	●	●	●	●	○	○	○	○	○	●	●	●	○	○	○	○	○	○	○	○	○	○	○	○			●	○	○	○	○		○	○
FAST/SPS fast sintering system	HP D	●	●	●	●	●	●	○	○	●	○	○	●	●	●	○	○	○	○	○	○	○	○	○	○	○	○	●	○					○	○	○	
FAST/Hybrid fast sintering system	H-HP D	●	●	●	●	●	○	○	○	●	○	○	●	●	●	○	○	○	○	○	○	○	○	○	○	○	○	●	○	●	○	○	○	○	○	○	○

Attention! Not all performance characteristics can be combined!

Available equipment

1. Fully Automatic Operation

As standard, our systems are equipped with high-quality, industry-standard program controllers based on Siemens S7 or Stange SE, which meet the requirements both in the scientific environment and in an industrial production environment. The software used is an in-house development by FCT Systeme. This ensures practical functionality with full utilisation of all system performance characteristics as well as the possibility to customise to your individual requirements.

The operation is simple and self-explanatory via the touch-sensitive TFT screen, which provides all the different required information screen images by means of selectable function keys. A standard keyboard can also be used for entering numbers and texts. The program controller allows fully automatic control or regulation of the system functions according to your specifications individually defined in the form of any number of recipe steps. So, you achieve a high reproducibility of the processes and can avoid costly and time consuming operating errors. Simple single-user to distributed multi-user systems with redundant servers and multi-site solutions with Web clients are possible; you are thus compatible with the requirements of "Industry 4.0".

2. Process Visualisation

On the large and clear screen, the respective system is depicted as a diagram with its individual components according to the technological mode of operation. The numerical/graphical representation of all relevant switching states and analogue values allows a simple yet complete overview of the system status. Because of their high efficiency the process visualisation is standard for all FCT Systeme systems.

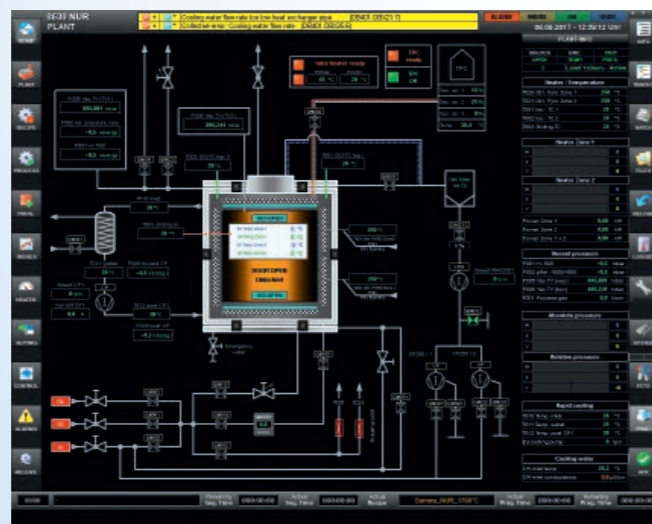

3. Self-Monitoring

The integration of numerous self-monitoring features into the program controller software is an important addition to process visualisation. In combination with the risk assessment according to EN ISO 12100, which was carried out during the design phase for each system, the optimal operational safety of our systems is guaranteed.

If one of the self-monitoring functions detects a relevant deviation, depending on the degree of threat, a warning or an error message is issued with varying consequences, including the controlled shutdown of the system, thus ensuring safe operation of the system.



Sophisticated alarm processing with stored error database and clear display of the alarm history facilitates the reaction to alarms and evaluation of stored events.

4. Data Logger

The chronological sequences of all the process data generated during the running process are clearly displayed on one freely configurable "trend screen" ("recorder function"). By automatically storing the data, the processes can be viewed at any time for viewing or for further analysis. An export function ensures that all data is available for detailed analysis using spreadsheet, statistics or graphics programs.

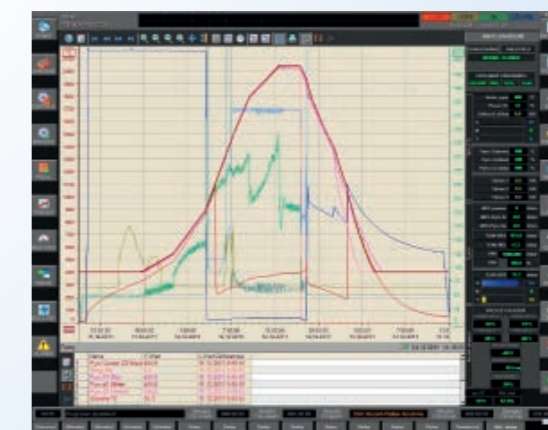

Available equipment

5. Recipe Management

The fully automatic sequence of the processes is defined via process step sequences (“recipes”) which can consist of up to 40 active steps (“segments”). For each segment you can specify the analogue set points and switching states. The jump into the next segment can be triggered by different jump conditions (e.g. time, temperature, etc.).

All functions needed to manage the recipes, such as: e.g. selection of existing, creating and saving of new recipes, input of recipe descriptions etc., are available and allow the user to work easily and efficiently with the system.



6. Max. Operating temperature 2200°C

The standard FCT System systems are generally designed for an operating temperature of 2200°C. This makes them ideal for the vast majority of typical applications.

7. Max. Operating temperature 2400°C

If, in special cases, working temperatures above 2200°C are required, this can usually be done by careful thermal and electrical design of the system, considering the particular application.

8. Max. Operating temperature 3000°C

The development of high-performance materials (e.g. UHTM = “Ultra High Temperature Materials” such as TaC and HfC) in rare cases even requires working temperatures well in excess of 2400°C. We can also design some of our systems for such extreme requirements.

9. Pyrometer Measurement Near Sample Centre

A special design of the top extrusion die opens the possibility of using a pyrometer (Pyrometer A) to measure and document the temperature in the immediate vicinity of the powder compact located in the pressing tool during the entire process. FEM simulations have shown that there is only a slight difference between the measured value and the temperature of the sample centre, whereas the usual measurement with a radially arranged pyrometer (pyrometer B) - in particular with FAST/SPS systems - can show errors of more than 100K.

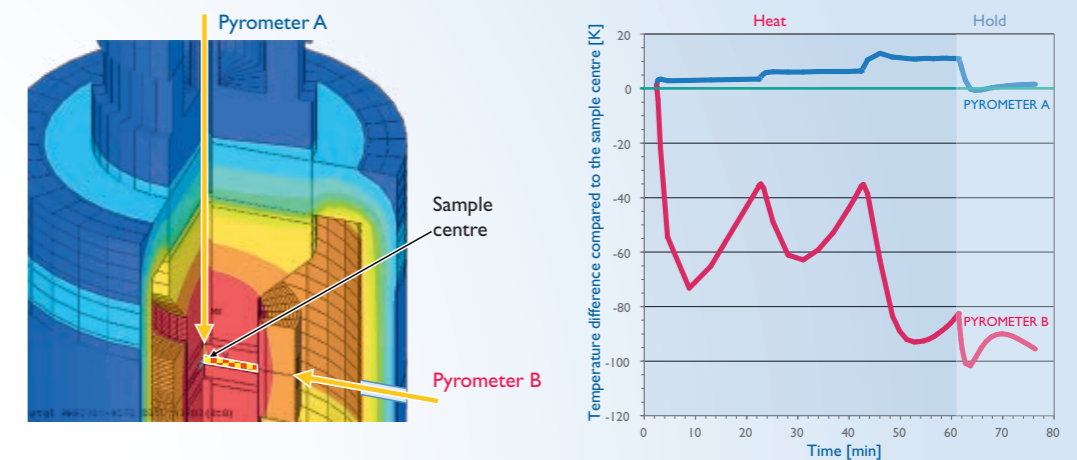

10. Pyrometer Measuring Range from 100°C

Optionally we can equip our systems with pyrometer-based temperature measurement, which offers a continuous measuring range of 100°C to 2400°C. This is particularly interesting for laboratory systems, which can be used very flexibly for different materials with a wide sintering temperature range.

11. Pyrometer in Quotient Measurement Mode

With particularly high demands on the precision, reliability and long-term stability of the temperature measurement, we can optionally equip our systems with quotient pyrometers, which measure the radiation flux at two different wavelengths and determine the temperature independently of the emission level.

Available equipment

12. Digitally Controlled Servo-Hydraulics

All our systems with extrusion dies are equipped with digitally controlled servo-hydraulics. Advantages include high flexibility, precise force/stroke control and low-noise operation.

13. Dilatometer

In the case of systems with mechanical pressing force, it is possible even in the standard version to visualise and record the sintering shrinkage of the components in real time via a highly accurate measurement of the extrusion die movement. Thus, the prerequisite is created for adjusting the process precisely to the sintering behaviour of the components including automated processes such as rate controlled sintering (see below). In systems without extrusion dies, in many cases an optional dilatometer unit can be installed, which offers the same possibilities.

14. Rate Controlled Sintering (via press force)

Usually, a process consists of a heating phase with one or more linear heating ramps and one or more holding temperatures. However, some materials show a very different thermal and/or pressing pressure activation of the various sintering mechanisms. This behaviour can sometimes be incompletely considered in the usual procedure. A material-oriented strategy, with which the material properties can be optimised in such cases, is the regulation of the sintering process considering the current compression speed ("RCS" = Rate Controlled Sintering). For hot pressing and FAST systems RCS via a regulation of the pressing force is possible.

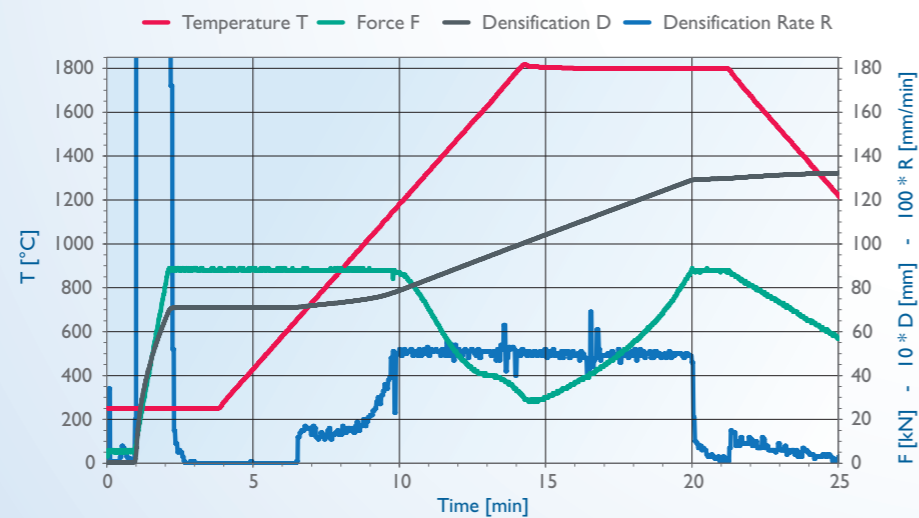

15. Rate Controlled Sintering (via temperature controller)

The regulation of the sintering process considering the current compression speed ("RCS" = Rate Controlled Sintering) can also be carried out by controlling the heating rate. This may have advantages over the press force control for certain materials. For hot pressing and FAST systems and all other equipment equipped with a dilatometer, this RCS mode is optional.

16. Fine Vacuum up to Atmospheric Pressure

All systems are equipped as standard with vacuum-tight furnace containers and vacuum pumps, so that a working gas pressure range of 0.05 mbar (absolute) up to 50 mbar above ambient pressure can be covered.

17. Fast Air Extraction

If, for material or efficiency reasons, a particularly rapid extraction of the air from the furnace container is required, we equip our systems with optional vacuum pump technology according to customer requirements.

18. High Vacuum

In most cases, the carbon-based components present in the furnace container (thermal insulation, heater, pressing tool, etc.) provide for a very low oxygen partial pressure in the furnace atmosphere. Nevertheless, it may be necessary in special cases to further reduce the gas pressure well below the standard minimum value. We can also meet these requirements as an option.

Available equipment

- 19. Overpressure up to 10 bar** A gas overpressure in the furnace container may be an effective means for some materials to suppress their thermal decomposition at high temperatures. The sintering HIP process also works with an increased gas pressure in order to achieve support for the sintering compression after the pore space has been closed by free sintering.
- 20. Overpressure up to 100 bar** If a gas pressure of 10 bar is not sufficient to suppress the decomposition of the material or to sufficiently compress the components in the sintering HIP process, some of our systems can optionally be designed for a gas pressure of up to 100 bar or higher.
- 21. Protective gas
(Ar, N₂, N₂ + 5% H₂)** By default, our systems are designed for oxygen-free operation, i.e. vacuum or use of all conventional protective gases and gas mixtures, as long as they do not reach the explosion limit (e.g. Ar, N₂, N₂ + 5% H₂).
- 22. Oxidising Atmosphere** If required, we can also supply systems that have an oxygen-containing furnace atmosphere (air to pure oxygen).
- 23. Oxygen Partial Pressure Control** Systems designed for an oxygen-containing furnace atmosphere may optionally also be equipped with a recipe-controlled oxygen partial pressure control.

24. Hydrogen Operation

For hydrogen operation or gas mixtures that are above the explosion limit, we can optionally equip our systems with appropriate control and safety technology to ensure safe operation in accordance with legal requirements.

25. Debinding

Optionally, our systems for combined debinding/sintering processes (“combination processes”) can be equipped with appropriate retorts with defined gas flow as well as the specifically required low temperature carbonisation gas disposal (thermal or catalytic afterburning).

26. Gas Supply in Retort

For some reaction sintering processes reactive gases are used, which require a defined gas flow. We can also equip our systems accordingly for this application. If necessary, this will be supplemented by appropriate facilities for exhaust gas treatment (flaring device, acid scrubber, dry absorber etc.).

Available equipment

27. Semi-Continuous/Separate Cooling Chamber

Through innovative features such as the FAST/Hybrid heating technology maximum heating rates can be achieved while minimising the temperature gradients in the component. However, system productivity is often limited by the time-consuming cooling phase, which is difficult to influence. A proven solution for this problem in day-to-day production is our semi-continuous system featuring a decoupling of sintering and cooling phase. The fully automatic combination of tool handling, vacuum lock and separate cooling chamber can significantly increase the cycle frequency and thus the cost

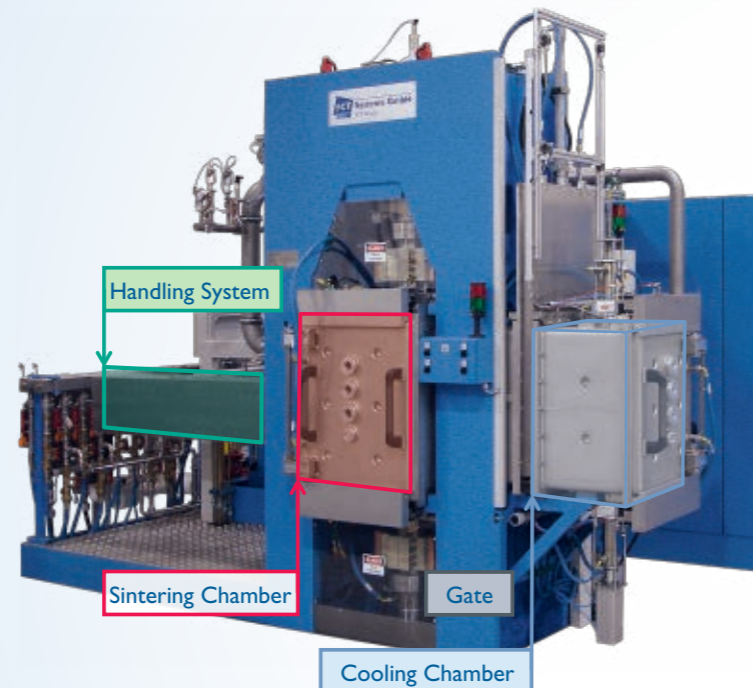

The principle of semi-continuous system technology is illustrated by means of the diagram of the temperature profile of the component in a two-chamber system compared to a single-chamber standard system. As you can see in the example shown, the 85 minute cycle can be reduced to 36 minutes, with only a relatively simple two-chamber semi-continuous system, thus more than doubling the productivity of the system.

By extending the cooling chamber to a cooling tunnel, lower cooling rates can be achieved without affecting the cycle time, as is required by some thermal shock sensitive materials.

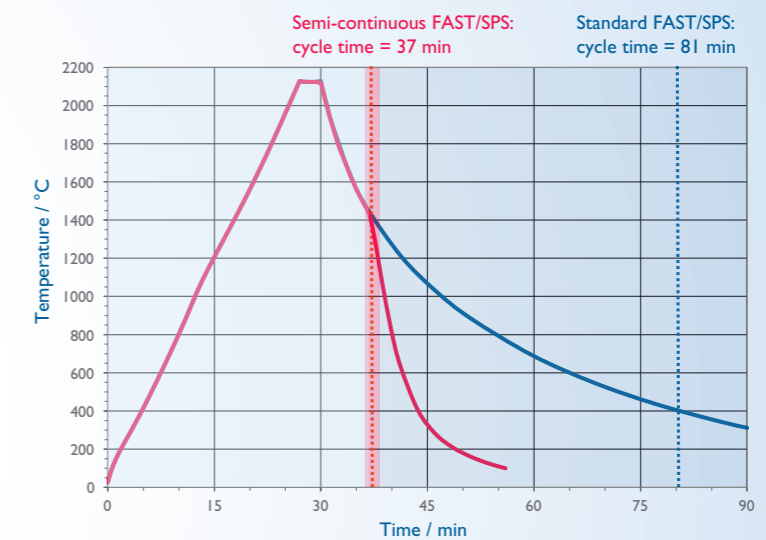

A further increase in productivity can be achieved if a preheat chamber or a preheat tunnel is connected upstream from the main sintering chamber, so that the time in the main chamber and thus the cycle time can be further reduced.

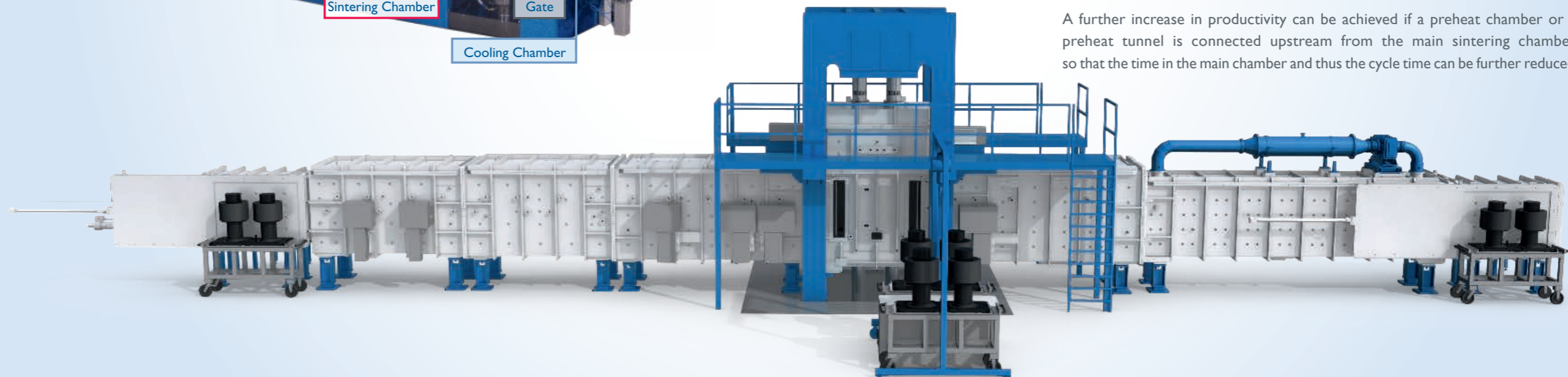

Available equipment

28. FAST/SPS
(high current density)
DC/pulsed DC

Our FAST/SPS systems ("FAST" = Field Assisted Sintering Technology, "SPS" = Spark Plasma Sintering) implement an innovative sintering technology used in the processing of many materials, e.g. it has become very important in nanostructured materials, composites and gradient materials. The process is based on a modified hot-pressing process, in which the electric current passes directly through the pressing tool and the component, rather than through an external heater. It can be heated very quickly and evenly in this way and short process cycles can be achieved.

This can suppress grain growth and the achievement of equilibrium states, allowing for materials with previously unattainable compositions and properties, submicron or nanoscale materials and composites with unique compositions.

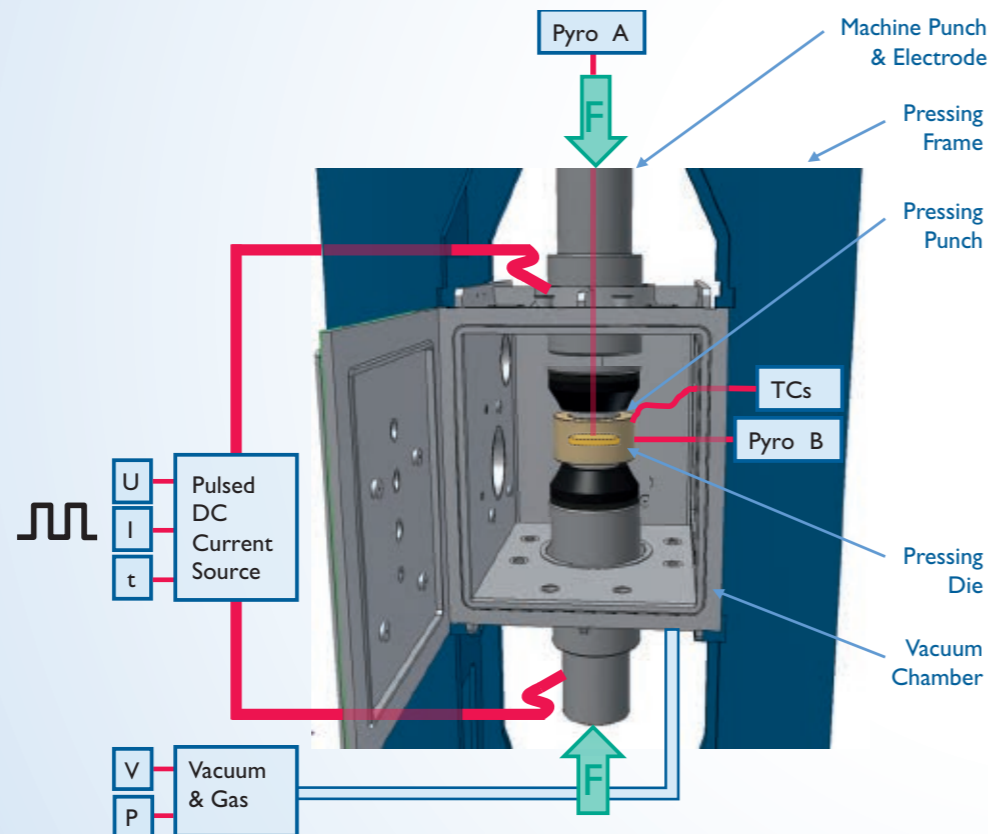

Due to the applied electric field, apart from the Joule heat, numerous other physical processes can be triggered in the powder compact - which have a sintering activating effect.

Potential Field Effects Assisting Sintering

POTENTIAL EFFECTS OF THE ELECTRICAL FIELD PROMOTING SINTERING

- Joule Heating
- Transport Phenomena
 - Electrodifflusion
 - Electromigration
 - Generation of Dislocations
 - Thermoelectric Effects (Peltier)
- Mechanical Force Effects
 - Electrodynamic Forces
 - Electrostriction
 - Particle Alignment
 - Electroplasticity
 - Pinch Effect
 - Ponderomotive Forces
- Surface Plasmons
- Multiple SHS (selfpropagating HT synthesis)
- Dielectric Phenomena
 - Polarization
 - Dielectric Breakdown
-

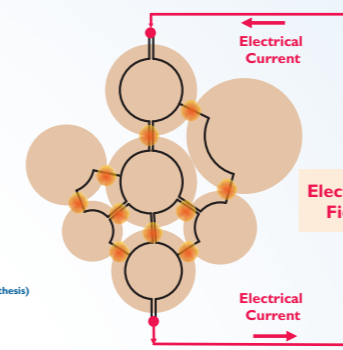

Potential Pulsed Field Effects Assisting Sintering

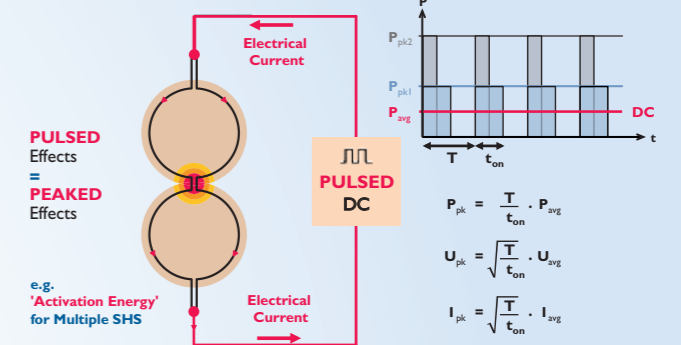

Depending on the material system, these effects can be further enhanced by the use of current pulses in comparison to continuous direct current.

Our FAST/SPS systems can vary the pulse parameters in a wide range and thus offer maximum flexibility in optimising the sintering activating effects.

Programmable DC Pulse Power Supply
Wide Range of Pulse Patterns up to Pure DC

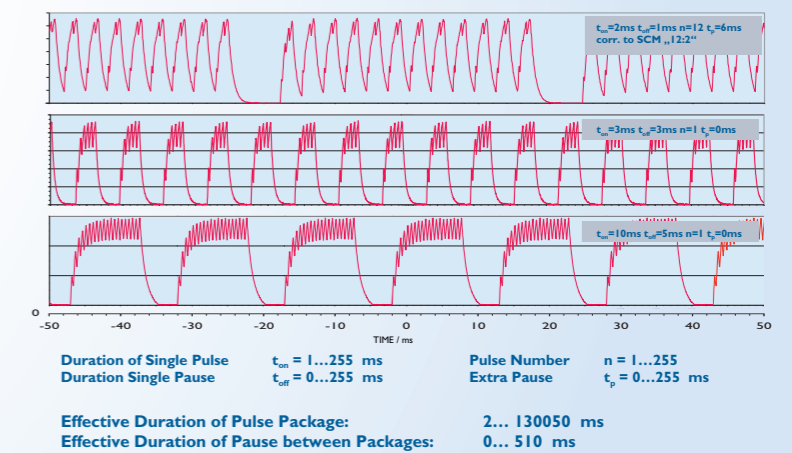

29. FAST/SPS
(high current density)
AC/pulsed AC

In special cases it may be necessary to use AC instead of DC in the FAST/SPS process. This is also possible as an option.

Available equipment

30. Resistance Heating

For most of our furnaces and hot presses, the use of resistance heaters with one or more heating circuits is a proven standard. But it can also be useful to equip the directly heated FAST/SPS systems with an additional resistance heater. This can e.g. be an important means to achieve a minimisation of the temperature gradients in the component even with large components and/or the highest heating rates. The so-called FAST/Hybrid systems can regulate both heating circuits independently of each other so that a compensation of the heat losses and thus a minimisation of the thermal gradient is achieved (see picture).

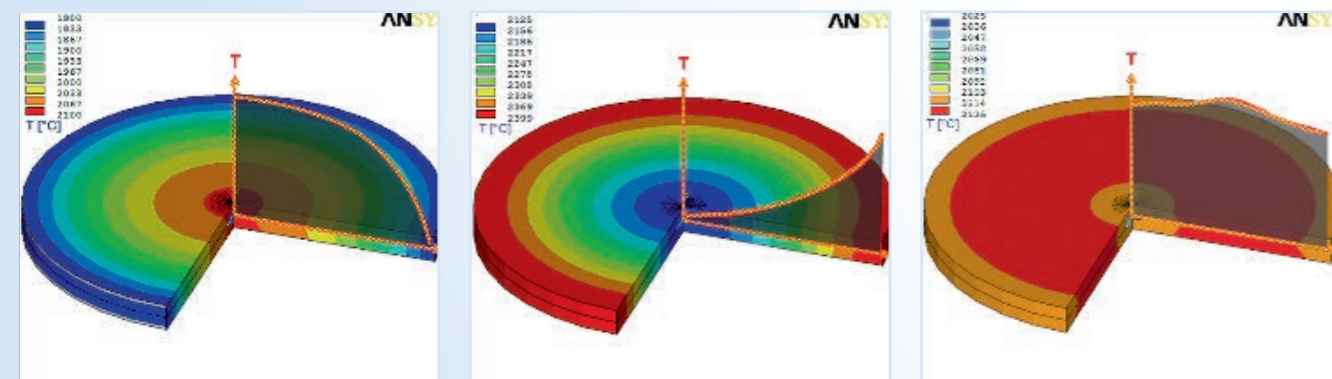
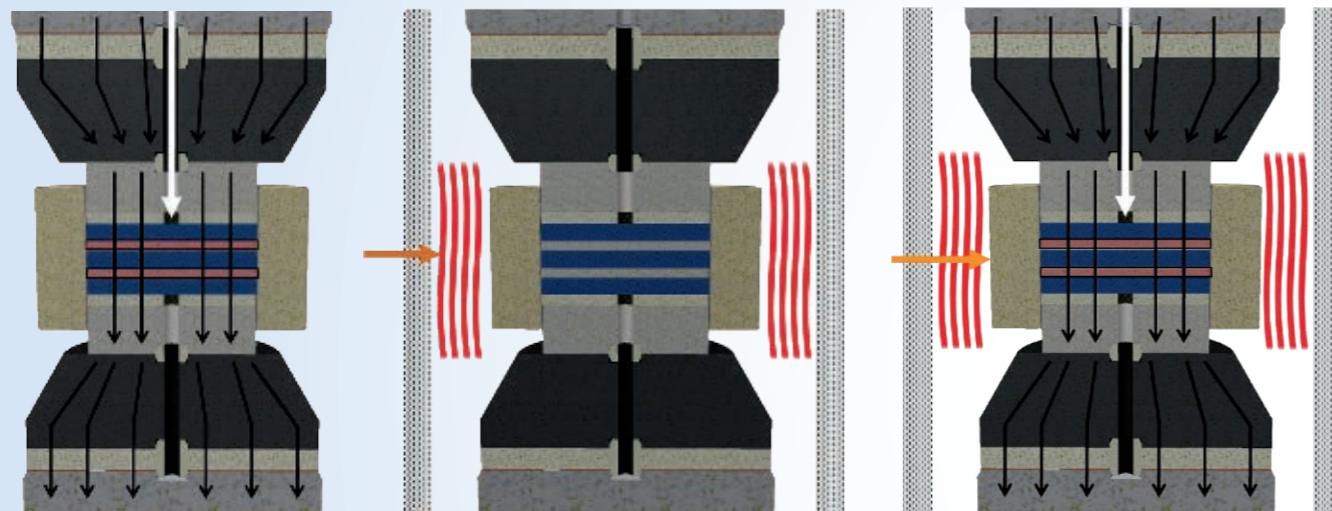

As the comparison of curves shows, the minimised temperature gradients not only allow the production of particularly homogeneous components with higher sintered density but allow a shortening of the process times due to the faster compression behaviour.

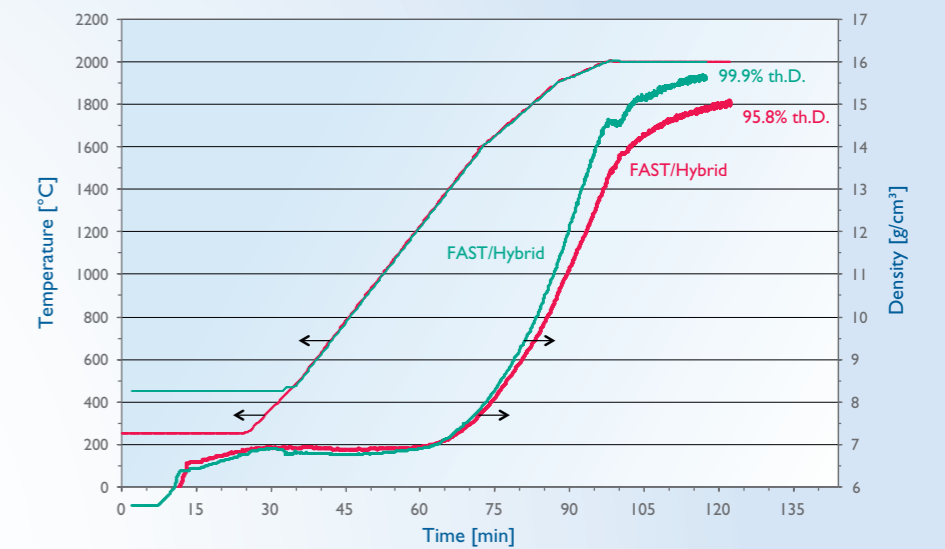

31. Induction Heating

Although induction heating is technically more complex compared to resistance heating, it has some advantages for the user:

- better utilisation of the space available in the container, thus higher useful volume of the furnace,
- higher maximum heating capacities and temperatures,
- in the case of FAST/Hybrid systems with induction heating, the press die simultaneously acts as a susceptor. In addition to the direct heating of the press tool centre together with the component, this also means direct heating of the press die, which allows a further increase in the maximum heating rates and/or minimisation of the temperature gradients in the component.

Available equipment

**32. FAST/Flash
(high electric field strength) DC**

Recent research has proved that materials with low electrical conductivity like most oxides (e.g. yttria-stabilised ZrO_2 , MgO-doped Al_2O_3) show a spontaneous compression effect with a critical combination of temperature and applied electric field strength. The non-pressurised variant is called “flash sintering”, while in so-called “flash sinter forging” the sample sits between extrusion dies.

For the investigation, further development and industrial application of this new sintering technology, we can upgrade our hot pressing and FAST/Hybrid systems to so-called FAST/Flash systems. In the case of the FAST/Hybrid, multipurpose systems of maximum flexibility are thus created, with which practically all relevant sintering technologies can be realised (free sintering, hot pressing, FAST/SPS, FAST/Hybrid, FAST/Flash). The diagram shows an example of some compression curves obtained with such a system.

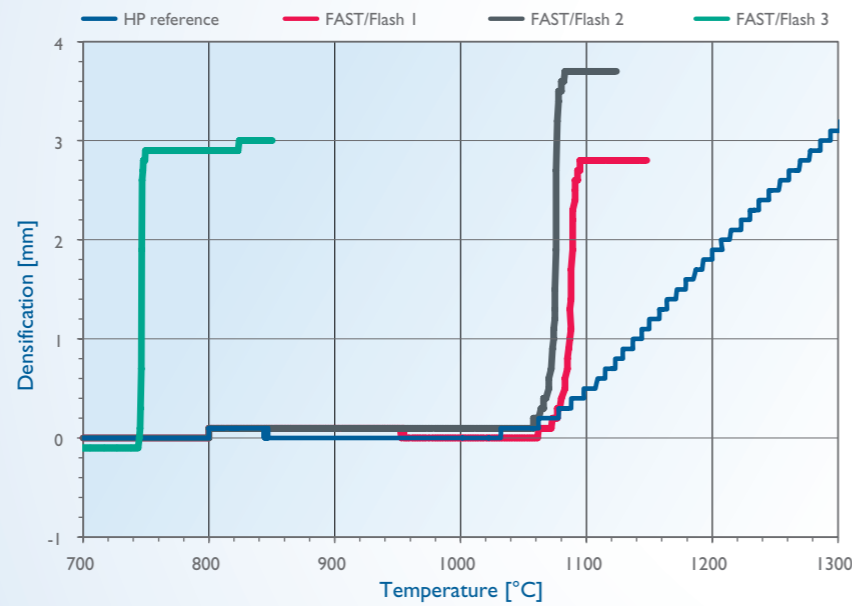

**33. FAST/Flash
(high electric field strength) AC**

In special cases it may be necessary to use an AC field instead of a DC field in the FAST/Flash process. This is also possible as an option.

34. Glove Box

For the processing of oxidation or moisture-sensitive powders or in the case of toxic starting materials, the use of a glove box to ensure adequate product or personal protection could be necessary. Optionally, therefore, some of our systems are supplied with a flanged glove box.



**35. Separate Cooling
Water Supply**

Our systems are equipped by default for connection to a central cooling water supply. If required, however, it is also possible to supply a self-sufficient cooling water system which is exactly adapted to the requirements of the respective system.

**36. Pressing Tools,
Kiln Furniture and
Other Special Accessories**

In order to put the customer's goods to be thermally treated into the furnace chamber, crucible or shelf-like accessories (“kiln furniture”) are usually necessary. Hot presses require pressing tools, into which the material to be compacted (compact or powder) is filled. All these accessories have a decisive impact on the efficiency and the qualitative result of the respective sintering process. That's why we give our customers valuable assistance in selecting, designing and manufacturing these indispensable parts, considering the individual remit of the customer and supportive use of numerical simulations (FEM).

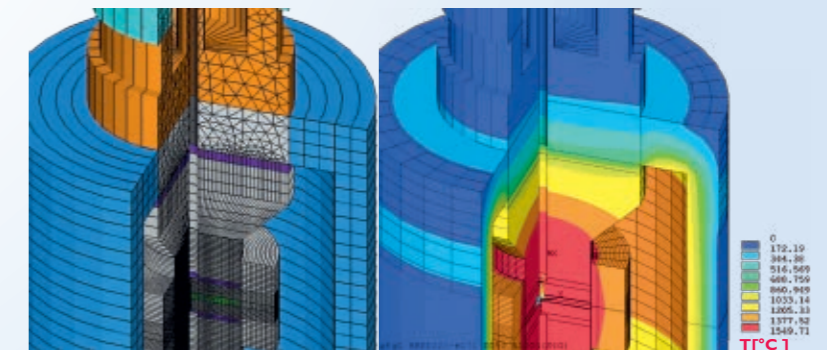





FCT Systeme GmbH

Gewerbepark 16 D-96528 Frankenblick

Phone: +49 (0) 36766 824 0 Email: info@fct-systeme.de

More Information: www.fct-systeme.de